

Annex 2: TEST METHOD TO ASSESS THE INFLUENCE OF STATIC CHARGE RETAINED ON MATERIALS

The following document was prepared by John Chubb (John Chubb Instrumentation Ltd) as the basis for a new British Standard. This work was carried out in 2004 for British Standards Technical Committee GEL101, which reports to IEC TC101.

Contents

Foreword

- 1 Scope
- 2 References
- 3 Definitions
- 4 Test method
- 5 Procedure
- 6 Assessment
- 7 Test report

Annex A Definitions

Annex B Design and operation of test apparatus

Annex C Measurement of charge decay time

Annex D Measurement of the quantity of charge transferred with corona charging

Annex E Environmental conditions

Annex F Assessment of capacitance loading measurements

Annex G Bibliography

Annex H Calibration of charge decay measuring instrumentation

Annex J Calibration of corona charge transfer measuring instrumentation

Foreword

The Test Method described in this Standard provides assessment of the suitability of materials to avoid risks and problems from the influence of static electric charge retained on the surface of a material after contact and rubbing actions with other materials. The basis of the method is:

- a) That most risks from static electric charge retained on materials relate directly to the local surface voltage created. The surface voltage indicates opportunity for direct air discharge (for voltages over about 300V), opportunity for charge induction on devices nearby (with risks of ‘charge device model’ type damage events) and opportunity for attraction of airborne particles.
- b) That there is a direct relationship between the surface voltage present at the time when practical surfaces separate after contact and rubbing actions and values of charge decay time and capacitance loading shown by the materials. Surface voltages will be limited to low values if the time for decay of surface voltage is very short and/or if the capacitance experienced by surface charge is very high.
- c) That the behaviour of materials in practical situations with tribocharging is well represented by measurements on sample areas of the material with corona charging.

1 Scope

The method of test described is concerned with assessing the performance of materials in relation to the influence of static charge retained after contact and rubbing actions. The influence of the surface charge is manifest in terms of the local surface voltage.

This Standard is not concerned with the character of electrostatic discharges to materials or with their shielding capability or with their ability to remove charge from conducting items in contact.

The method of test can be used with any fairly flat surface material (for example as sheet, film and layer) as well as with powders and liquids held in suitable containers.

2 References

2.1 Informative references

A number of published papers relevant to the present Standard are listed in Annex G.

3 Definitions

For the purpose of this standard, the definitions in Annex A will apply.

4 Test Method

Measurements are made on a single layer area of material (for example the fabric of a garment or a sheet or layer) supported flat from an earthed edge support. Measurements are made both with 'open backing', where there are no earthed or charged surfaces nearby, and with the whole test area resting against a clean earthed metal surface. These conditions model the two extremes of practical applications.

The test method is equally applicable to installed surfaces and to powders and to liquids.

A localised patch of charge is deposited in a short period of time in the middle of the test area. This may be deposited by tribocharging or, more conveniently, by a high voltage corona discharge, as described in Annex B. Corona charging may be used as studies have shown that the performance of materials matches well that obtained with tribocharging. A number of relevant references given in Annex G.

The surface voltage created by the deposited charge is measured and the rate of decay of this voltage with time is measured with open and earthed backing, as described in Annex C.

The quantity of charge transferred by the charging action is measured, as described in Annex D.

The performance of materials is likely to vary considerably with ambient environment of temperature and humidity. These parameters need to be controlled and measured, as described in Annex E.

5 Procedure

5.1 Mounting

Mount the test surface into the corona charge decay apparatus as described in Annex B.

5.2 Environmental conditions

Set conditions of temperature and humidity as described in Annex E. Condition samples in these environments for at least 24 hours

5.3 Pre-test surface voltage

Check pre-test surface voltage adequately low before each test. This should be less than 2% of the expected or observed initial peak surface voltage achieved at charging.

5.4 Charge decay times

Measure charge decay times and capacitance loading values using both +ve and -ve polarity charging. Make at least 2 measurements with corona durations of 10 or 20ms at each of the following corona voltages:

+ve (kV)	-ve (kV)
	2.7
3.0	3.0
4.0	4.0
5.0	5.0

NOTE: With this range of corona discharge voltages measurements are made of surface voltages and associated quantities of charge for both polarities over a range of quantities of charge down to a few nanocoulombs (nC). This covers the conditions that relate to tribocharging situations.

NOTE: Additional measurements will be needed if measurements show much variation with position over the tests sample.

5.5 Decay time measurement

Measure the time for the decay of each surface voltage from that at 0.1s after the end of the charging action to 10% of that at 0.1s.

NOTE: It is not necessary to achieve any specific initial surface voltage, only sufficient for good quality decay time measurement.

5.6 Capacitance loading

Calculate values for capacitance loading from each initial voltage value and its associated quantity of charge transferred, as described in Annex F.

5.7 Analysis of capacitance loading values

Plot values of capacitance loading against quantities of charge. Extrapolate the average slopes of variation for positive and negative polarity to zero charge – as illustrated in Annex G. The values of positive and negative capacitance loading at zero charge are averaged and noted.

6 Assessment

The assessment of materials is based on the surface voltage measured 0.10s after the end of a short period of charging.

Judgements are made from either of the two performance features:

- a) whether the times for the surface voltage to decay from the value observed at 0.1s to 10% of this with open and also with earthed backing is less than a specified time, t(a)

and/or:

- b) whether the capacitance loading value extrapolated to zero charge, based on the surface voltage at 0.1s, is greater than N and also that the time for the surface voltage to fall from the 0.1s value to 10% is less than t(b).

For general applications t(a) shall be 1s, N shall be 40 or more and t(b) shall be 20s.

If it is clear from initial measurements that capacitance loading values are too low for effective control of surface voltages then measurements can concentrate on charge decay time measurements.

If it is only practicable to measure the charge decay time (for example with installed surfaces) then this measurement will be sufficient so long as the decay time t(a) is less than the acceptance time, for example 1s.

The 'voltage at 0.10s' is affected by the charge decay after the end of charging and also by the capacitance loading experienced by the surface charge. The choice of 0.1s relates to the time taken in tribocharging actions for the influence of surface charge on nearby items to develop as the contacting surfaces separate.

If the time for charge decay after the 0.1s is short compared to the time of separation of surfaces, and also if there is a route available for the charge to leak away to earth, then no significant surface voltages can arise.

The maximum surface voltage V_{max} (volts) that may arise in practice for a quantity of charge q (nC) can be obtained from the capacitance loading values extrapolated to zero charge as:

$$V_{max} = f q / (CL_{q=0})$$

- where f is a factor and $CL_{q=0}$ is the value of capacitance loading measured with corona charging extrapolated to zero charge. In practice values for q are likely to be no more than 50nC and the factor f has a value around 75.

NOTE: Extrapolation of capacitance loading values to zero charge has been found the best way to match corona charging to tribocharging performance.

The maximum voltage values derived as above can be compared to risk threshold voltage levels for practical situations. For example, if the maximum surface voltage permissible is 100V then capacitance loading value needs to exceed 40.

In addition to the capacitance loading requirement above, it is necessary that any locally generated charge can drain away to earth. If not then multiple charging actions will lead to a progressive build up of surface potential. Assuming that the material has an earth bonding point (for example the body of a person inhabiting a garment is earthed via footwear or a wrist strap), then the time for charge decay to 10% of the value achieved at 0.10s shall be less than 20s with earthed backing. For the case of garments where the area charged may be across a seam from the earth bonding connection then measurements need to be made both where a seam separates the earthing point and the test area and when the earthing connection is on the same area of fabric as that directly charged (as described in Annex F).

7 Test Report

The test report shall include at least the following information:

- a) date and time of measurements
- b) description and/or identification of material tested
- c) description and/or identification of reference tested
- d) corona charging conditions used (e.g. polarity, corona voltage, charging duration)
- e) whether the sample is supported with an 'open backing' or an 'earthed backing'
- f) individual values of initial surface potential values achieved 100ms after the end of the charging action and the associated times for this voltage to decay to 1/e of this and also to 10% of this. Where multiple measurements have been made it is appropriate to plot the variation of charge decay time with quantity of charge. Results shall be shown and quoted separately for measurements with open and earthed backing. Different polarity measurements may be combined.
- g) individual values of initial surface potential, quantity of charge transferred and capacitance loading. The variation of capacitance loading with quantity of charge is plotted to show the extrapolation to values at zero charge. Results shall be shown and quoted separately for measurements with open and earthed backing. Different polarity measurements may be combined.
- h) mean charge decay time and the capacitance loading values at zero charge
- i) temperature and relative humidity at the time of testing and time for which samples were exposed to these conditions before testing
- j) identification of instrumentation used (e.g. type and serial number) and date and certificate details of most recent calibration (as per procedures described in Annex H and Annex J)

Annex A: (Normative)

DEFINITIONS

A1 capacitance loading

the surface potential achieved per unit quantity of charge for a thin film of a good dielectric divided by the surface potential achieved per unit of charge with a similar surface charge distribution on the test material

A2 charge decay

the migration of charge across or through a material leading to a reduction of surface potential at the area where the charge was deposited

A3 charge decay time

The time from the initial surface voltage level created by the charge put on to the surface (100%) to a selected, and a stated, end point fraction of this. The initial voltage value to be used is that 0.1s after the end of a short period charging action.

NOTE: Convenient decay times for comparison between materials are the time from the initial surface voltage to 1/e of this (e is the base of the natural logarithm 2,7183) and to 10% of this.

NOTE: As the rate of charge decay may vary greatly during the progress of decay it is very useful to record the form of the variation of surface voltage with time.

A4 conductive material

a material with a high mobility of charge so that the potential on the surface is retained for only a very short time

NOTE: The charge decay time of conductive materials is generally less than 0.05 s.

A15 corona

the generation of ions of either polarity by a high localised electric field

A6 dissipative material

a material which allows charge to migrate over its surface and/or through its volume in a time that is short compared to the time scale of the actions creating the charge or the time within which this charge will be effective or will cause an electrostatic problem.

NOTE: For general avoidance of risks and problems in operations involving manual activities the decay time from the initial surface voltage at 0.1s to 10% of this needs to be less than 1.0 s. To avoid the risk of incendiary sparks the decay time needs to be longer than 0.01s.

NOTE: The dissipative capability of a material does not relate to its ability to remove charge from a conducting item in contact. This ability is determined by resistivity type measurements.

A7 insulative material

a material with very low mobility of charge so that charge on the surface is retained there for a long time

NOTE: The charge decay time of insulative materials is generally greater than 10 s.

A8 relative capacitance

(see capacitance loading)

A9 surface potential

the reading from a non-contacting electrostatic voltmeter or fieldmeter in the test equipment calibrated in terms of the potential on a plane conducting surface covering the equipment test aperture

Annex B: (Normative)

DESIGN AND OPERATION OF TEST APPARATUS

B1 Physical design features

A typical arrangement and relevant dimensions of the test apparatus is shown in Figure B1. Other equipment fulfilling the basic design and performance requirements may be used.

The test aperture for deposition and measurement of deposited charge shall be 50 mm \pm 1 mm diameter or an equivalent quasi-square aperture area. The corona points are mounted on a movable plate in a 10 mm \pm 1 mm diameter circle, 10 mm \pm 1 mm above the centre of the test aperture.

The fieldmeter sensing aperture shall be 25 mm \pm 1 mm above the centre of the test area. When the plate with the corona points is moved fully away, the test area shall be clear up to the plane of the fieldmeter sensing aperture.

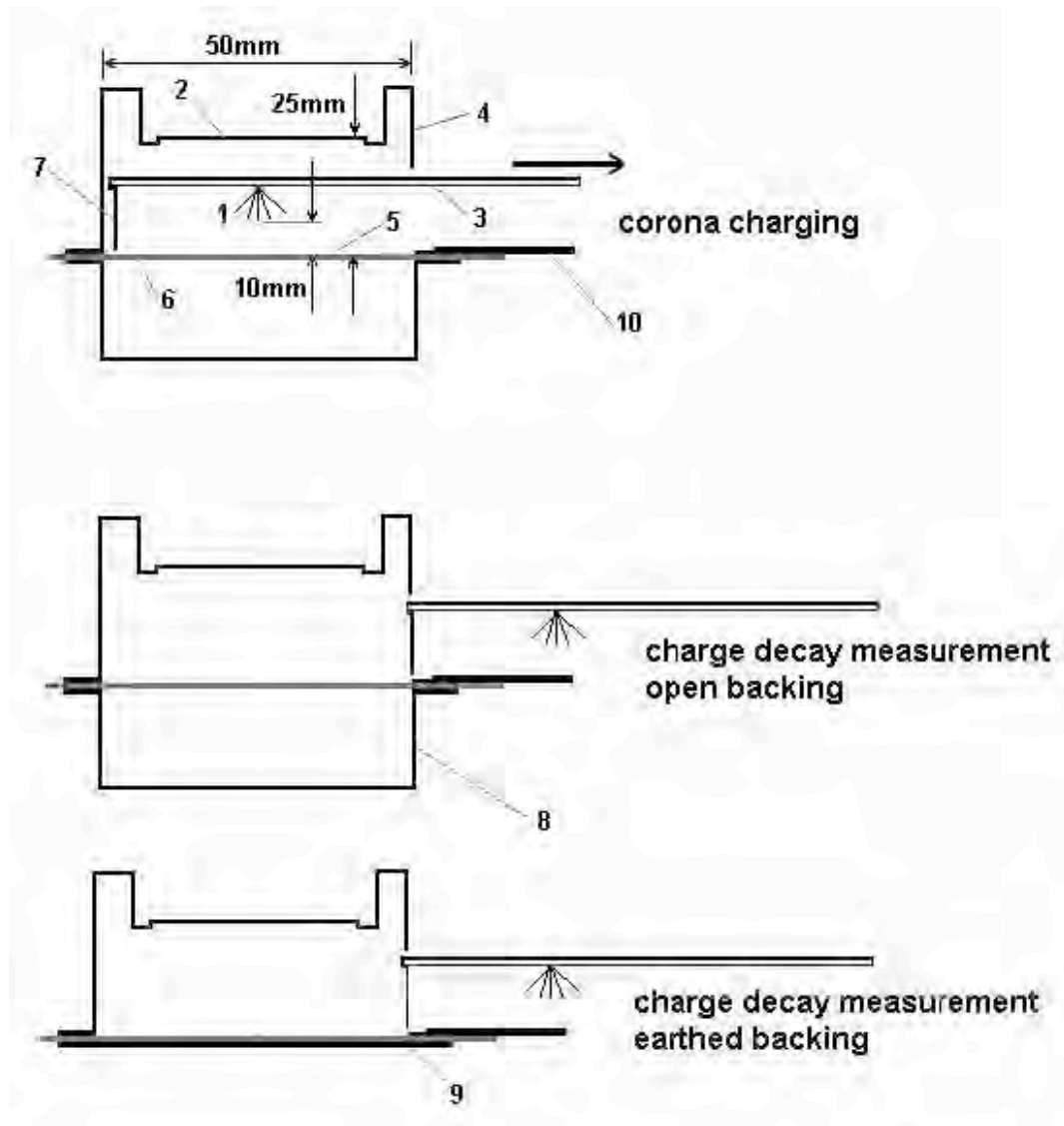

Figure B1 – Example of an arrangement for measurement of corona charge decay and arrangements for ‘open backing’ and ‘earthed backing’

Key to figure 1:

1 - 10 mm diameter circle of corona points

2 - Fieldmeter sensing aperture

3 - Movable plate

- insulating surface mounting corona points

- earthed top surface to shield fieldmeter
- 4 - Earthed casing
- 5 - Test aperture: 50 mm -0/+5 mm diameter or $(50 \text{ mm} \pm 5 \text{ mm}) \cdot (50 \text{ mm} \pm 5 \text{ mm})$ area
- 6 - Specimen under test
- 7 - Air dam to remove residual corona air ionisation
- 8 - Open shielded backing
- 9 - Earthed backing
- 10 - Instrument base plate

B2 Containment of test material

With an installed material the test aperture in the base plate of the instrument shall be rested directly on its surface.

Sheet or flexible materials shall be tested whilst supported against the test aperture with both 'open backing' and 'earthed backing'. These two arrangements (shown in Figure 1) represent the extreme conditions of practical application. For both arrangements the longer of the two decay times shall be taken for comparison with general acceptance criteria.

In practical terms, 'open backing' measurements represent the condition where materials are well separated from earthed surfaces, for example the bottom edge of a coat or smock hanging away from the body of the wearer. 'Earthed backing' represents the other practical extreme of a material resting in intimate contact with an earthed surface, for example a garment fitted close to the body of the wearer, or a work surface on top of a metal bench. The nature of the material used as an 'earthed backing' surface may affect measurements, so a suitable material needs to be used. For example, the insulating nature of anodised aluminium will inhibit vertical charge migration.

For testing of material with 'open backing' the material shall be supported against the base plate of the instrument by an earthed metal aperture aligned with the instrument test aperture and with at least 5 mm width outside the test aperture area. . The shield over the reverse side of the test area shall be earthed and at least 25 mm away over the whole test area.

For testing of materials against an 'earthed backing' the material shall be supported against a flat earthed conducting surface and the base plate around the test aperture. The earthed backing surface needs to be smooth, flat and free of insulating oxide films.

If charge moves more readily through the bulk test material than across its surface, then placing an earthed metal plate immediately behind the test area may decrease the charge decay time. On the other hand, if charge moves more readily across the surface of the test

material, then charge decay time may be increased due to increased capacitive loading.

For testing thin flexible films the film needs to be well tensioned to reduce risk of flexing during decay time measurements.

Powders and liquids may be tested while supported in an earthed metal cup beneath the test aperture. When testing light powders that may be easily dispersed into the air, precautions shall be taken to avoid powder particles becoming deposited on surfaces around and inside the fieldmeter sensing region. This may be achieved by, for example, slow retraction of the moving plate and air dam or by an appropriate increase in the separation between the powder surface and the plane of the sensing aperture.

B3 Corona charge deposition

The exact size and distribution of charge deposited on the material is not well defined. The arrangement provides a consistent pattern of deposited charge for decay time and capacitance loading measurement.

The corona charge deposition time shall be $20 \text{ ms} \pm 10 \text{ ms}$. Longer times may be used if needed to achieve an adequate initial peak surface potential for measurement. Corona deposition times longer than 100 ms will not necessarily provide any enhancement of charging and may create some damage to sensitive surfaces. Samples shall be tested with both positive and negative polarity.

NOTE: Typical voltages for corona charging are between 3kV and 10kV.

The equipment for charge deposition shall move fully away from the region of fieldmeter observation in less than 30 ms.

NOTE: For corona voltages up to 10 kV the initial surface potential with insulative materials will be up to about 3 kV. For materials with fast charge decay rates and/or high values of capacitance loading the initial surface potential may be much lower - for example only 50 V to 100 V. For low quantities of charge corona voltages down to about 3kV may be appropriate.

B4 Fieldmeter

The fieldmeter shall be able to measure the surface potential with an accuracy of $\pm 5\text{V}$, or better, with a response time (90% to 20%) less than 10 ms. The stability of the zero shall allow measurement of surface potential with this accuracy over the longest decay times to be measured.

NOTE: In measurements of capacitance loading with low corona voltages and small quantities of charge initial surface voltages may be quite low. It will be helpful if surface voltage measurements can be made to an accuracy of $\pm 1\text{V}$ down to zero volts.

The sensitivity of the fieldmeter shall be set according to the calibration procedure in Annex B to show the surface potential as presented by a plane conducting surface over the full area of the test aperture.

NOTE: A rotating vane 'field mill' type fieldmeter is preferred. Chopper stabilised sensors may be acceptable if the sensitivity, noise levels and zero stability are appropriate. Induction probe instruments are not likely to be suitable, even for fast charge decay measurements, because the influence of even slight residual corona air ionisation will cause zero drift – and the absence of this would need to be tested.

During corona charge deposition and decay time measurement the sensing aperture of the fieldmeter shall be well shielded from any connections or surfaces associated with corona high voltage supplies. There shall be no insulative materials in or around the region of the instrument between the fieldmeter and the test aperture able to contribute signals to fieldmeter observations.

For measurements with materials having initial peak surface potentials less than 200 V it is necessary to remove residual air ionisation created by the corona discharge when the moving plate carrying the corona discharge points is moved away. An air dam on the trailing edge of the moving plate mounting the corona discharge points is a convenient way to remove this air ionisation from the region between the fieldmeter sensing aperture and the test surface. Residual ionisation shall contribute less than 30 V to measurement of surface potential. This may be tested by measurements on a clean earthed metal test surface.

The value taken of the initial peak surface potential measured by the fieldmeter will be affected by the initial rate of charge decay and the time for removal of the plate carrying the corona discharge points. When the time for removal of the plate is comparable to the rate of decay, the time for plate movement will affect the value of the initial peak surface potential and hence the value of capacitance loading calculated.

For the present purpose of assessing the suitability of materials by modelling the behaviour observed with tribocharging it is appropriate to use the voltage measured at 0.1s after completion of the charging action to define the 'initial voltage'.

Annex C: (Normative)

MEASUREMENT OF CHARGE DECAY TIME

C1 Decay time

The 'charge decay time' is the time from an initial voltage created by the charge put on the surface to a selected, and a stated, end point fraction of this.

With tribocharging there is no influence on items nearby from the charges on the separating surfaces for about 0.1s. This arises from the timescale of body actions and the proximity between the separated charges. While charge decay behaviour with corona charging immediately after completion of the charging action is of technical interest it is not relevant to the practical performance and risks that can be created. The initial voltage value to be used is therefore that 0.1s after the end of the charging action.

The fraction of the initial voltage for the end point of charge decay time may be 1/e or 10%. These are designated as $t_{1/e}$ and $t_{10\%}$.

NOTE: The time from the initial voltage to 1/e of this should not be considered a 'time constant'. This would imply the decay curve followed an exponential form – and this is not generally true.

C2 Initial voltage

The form of variation of surface voltage with time after the end of the charging action in general varies little with the quantity of charge transferred. Thus the level of voltage reached at 0.1s after the end of the charging action is not directly important. All that is required is that at 10% of this voltage it is still possible to make good quality determination of the end point of timing.

Note: Care needs to be taken in the measurement of charge decay times on small signals where signal noise may be significant in relation to signal amplitude. Any signal averaging technique needs to take account of the need for a fast response on the fast initial transients of short decay time curves.

C3 Voltage decay curve

It is useful to record the form of the charge decay curve. In many cases the rate of decay slows up significantly during the progress of decay and appreciable levels of surface charge may be retained for long periods. This effect is also indicated by comparison of the decay times to 10% with that to 1/e.

NOTE: Records of charge decay curves allow future re-examination of performance

C4 Timing measurement

Decay times may be measured either directly by electronic circuits or on oscilloscope recordings of observations. To overcome signal to noise limitations at low signal levels

some local averaging of measurements may be needed - rather than operating simply in terms of maximum and minimum signal values.

C5 Measurement procedure

Where decay times are less than 100 s it is useful to make a number of repeat measurements at the same location and to make measurements with high and low corona voltages and with both polarities of charging. These measurements will demonstrate consistency in material behaviour, variations of performance with quantity of charge.

NOTE: It is desirable to make measurements to check if corona is causing any change in sample characteristics, both regarding charge decay time and capacitance loading. Any changes by corona may conveniently be examined by making measurements at the same location initially at low corona charge, then at high corona charge and then again at low charge.

The form of charge decay curves may have some variation with the quantity of charge deposited. It is wise to make tests over a range of quantities of charge comparable to those likely to arise in the practical situation. Tribocharging by rubbing may involve quantities of charge in the range 10-50nC. It is hence appropriate to make measurements with quantities of charge from 50nC downwards.

C6 Overcoming pre-charging

Sample surfaces may become pre-charged by handling when placing ready for testing. It is recommended that when samples are placed in position the moving plate is back, so the fieldmeter can respond to any charge on the sample surface and show these observations. This initial surface potential on relatively insulating samples may be minimised by careful handling with minimum sliding actions.

Appreciable pre-charging means surface voltages more than 2% of the expected or measured value of initial peak voltage. Large voltages than this may affect the results of decay time measurements to 10%.

Two main options are available if there is appreciable pre-charge:

- to wait until the pre-charge has dissipated. This means waiting for the initial surface potential to fall.
- to make a study on the decay of this pre-charge without adding any corona charge. This means making a measurement with the corona voltage turned off or set for zero volts. It is to be noted that the decay of such pre-charge may be rather slower than the decay of the local patch of corona charge. It is none the less a useful observation.

It is not recommended that quality measurements are attempted by putting corona charge on to an already well charged surface or material.

It is also not recommended that pre-charge on the material is neutralised by any means

other than waiting. Deposition of neutralising charge may only give the appearance of neutrality by creating close-coupled regions of charge.

C7 Additional artefacts to avoid

There are three other possible artefacts are worth noting:

- that if the air dam on the leading edge of the moving plate touches the sample surface then tribocharging may occur. This may arise when testing light fabrics. The fabric surface should be stretched flat under the test aperture, but it may still rise by induced air movement. This effect may be checked by making measurements with no corona charging. It may be avoided by slightly raising the base plate of the instrument off the sample.
- that with some materials a very short (1 ms to 2 ms) transient peak surface potential may be observed before the real charge decay curve. This is usually positive. Occurrence of this transient will upset operation of software timing. This is thought to be due to vertical charge separation between front and back surfaces of the sample at sample flexing.
- that if static charge is retained on the surface of the moving plate facing the test surface then charge may be drawn over the sample by the induction electric field. This effect may be minimised by minimising the non-earthed area on the underside of the moving plate.

C8 Calibration

The performance of the decay time measuring instrumentation shall be assessed according to the calibration procedure in Annex H.

Annex D: (Normative)

MEASUREMENT OF THE QUANTITY OF CHARGE TRANSFERRED WITH CORONA CHARGING

The charge received by a sample surface with corona charging can be measured using a sample support arrangement as illustrated in Figure D1.

The aperture for the sample in the mounting plates needs to be larger than the test aperture in the base plate of the charge decay test unit to avoid direct corona charge flow to these plates. This may be tested by checking for negligible ‘conduction’ charge signal in the absence of a sample. The performance of the surface charge measuring instrumentation shall be assessed according to the calibration procedure in Annex C.

The charge transferred to the test surface is measured in two parts:

- 1) as charge directly coupled to the sample mounting plates;
- 2) as charge remaining where it is deposited.

Note: The apparently simple approach of measuring the charge leaving the charge decay test unit will not give correct values for charge. The reason is that if charge is retained on the surface of the test material, and does not move quickly out to the sample mounting plates, it will couple back to the structure of the unit and so not be fully available for measurement.

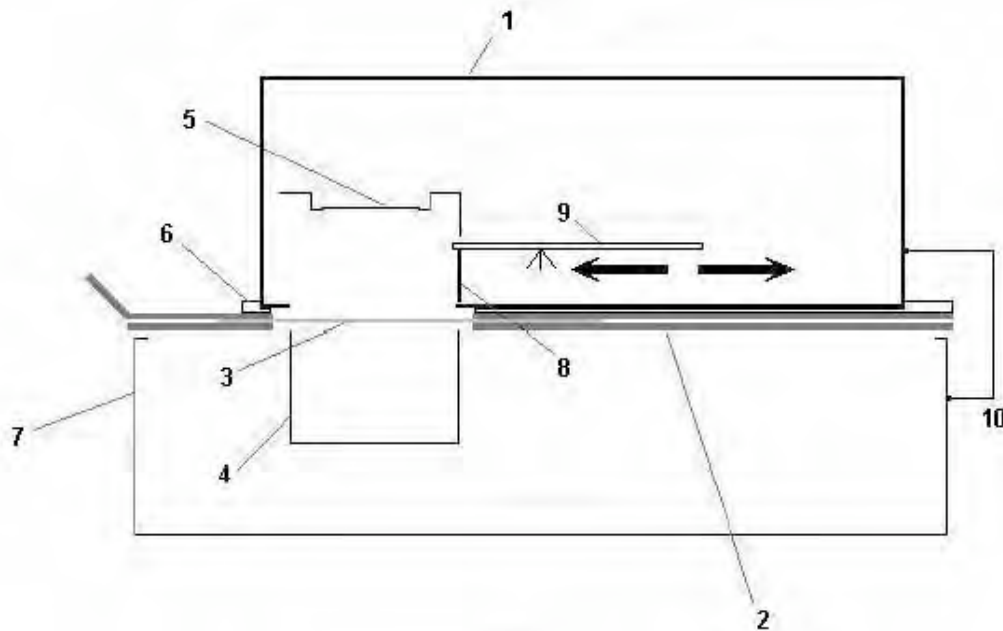

Figure D.1 – Arrangement for measuring received charge

Key:

1 Charge decay test unit

2 'Conduction' charge measuring support plates

3 Sample

4 'Induction' sensing electrode

5 Fieldmeter sensing aperture

6 Insulation between charge decay test unit and sample mounting plates

7 Shielding box

8 Air dam

9 Moving plate with cluster of corona discharge points

10 Earth bonding link from charge decay test unit to shielding box and 0V of charge measurement circuits

The 'conduction' charge coupled directly, and within the time of the observations, to the mounting plates is measured by a suitable virtual earth charge measurement circuit. The charge remaining in the area of deposition is sensed by an induction electrode beneath the open-backed sample. If the form of the induction sensing electrode is similar to the mechanical form of the charge decay apparatus above the test area then the retained charge will couple about half to the equipment and half to the induction electrode. The induction charge component will then be twice the charge received by the induction electrode.

The precise sensitivity of induction charge measurements and overall calibration of the charge measurement unit is determined as specified in Annex J.

Annex E: (Normative) ENVIRONMENTAL CONDITIONS

E.1 Standard environmental conditions

The charge decay properties of materials often vary with temperature and relative humidity. It is hence very important that the values of these parameters in the test environment are known, and that they are controlled to agreed values for standardised measurements.

To assess whether materials are significantly susceptible measurements should be made with at least 2 levels of humidity, one around 50%RH and the other below 25%RH. If materials are to be used in conditions outside this range of the above standard values (in particular at lower levels of humidity) then their characteristics must be checked under the most extreme conditions likely to be encountered and these conditions reported.

For standardised laboratory measurements samples shall be conditioned in the selected environmental conditions for at least 24 h before testing and measurements made with the conditions shown in Table 1 and in the listed sequence, or as otherwise agreed.

	Temperature	Relative humidity
	°C	%
1 High relative humidity	23 ± 2	50 ± 3
2 Low relative humidity	23 ± 2	12 ± 3

Table E.1 – Environments for conditioning and testing

For measurements in practical situations the ambient temperature and relative humidity shall be recorded.

Samples need to be stored in the set environmental conditions in ways that allow air circulation to both surfaces.

Operation of the test equipment may generate heat that will change the temperature and humidity conditions to which the sample is exposed inside the equipment relative to those outside and to which the samples have accommodated. Precautions need to be taken to reduce such changes.

NOTE: It is desirable to measure temperature and humidity within the test equipment to establish that there are no problems. It is also desirable to store samples with easy air circulation and not in the test position.

E.2 Sample handling and preparation

Handle samples only well away from the area to be tested or using tweezers. Avoid breathing in the direction of the sample.

The surface of the material tested shall be clean and free of loose dust. Remove any loose dust by gentle brushing or blowing with clean, dry air. If the surface is obviously contaminated either an alternative area or sample shall be tested, or measurements made with the contamination present and the condition of testing reported to be ‘as received’.

NOTE: Solvent or chemical cleaning is NOT recommended, as this may change surface conditions.

For measurements in practical or installed applications, the materials shall be tested without any “special” cleaning. If cleaning is part of the process, for example washing of garments, measurements should be taken before and after cleaning where practical. The materials and the method used to clean shall be reported.

Annex F: (Normative)

ASSESSMENT OF CAPACITANCE LOADING MEASUREMENTS

F.1 Calculation of ‘capacitance loading’ values

The capacitance effect experienced by charge on the test surface is best defined as the ratio of the surface potential achieved per unit of charge for a thin film of a good dielectric divided by the surface potential achieved per unit of charge with a similar surface charge distribution on the test material. This may be thought of as a ‘capacitance loading’ or as the ‘relative capacitance’.

The capacitance loading experienced by charge on the surface is obtained from measurement of the charge received by the test surface, Q , and the initial surface potential, V , observed. The value is calculated by comparing the observed ratio of initial surface potential per unit of charge to the ratio observed with a very thin layer of good dielectric (e.g. cling film) that has a sufficiently short decay time that a low pre-test surface potential can be achieved in a reasonable time. This ratio is equivalent to the ratio of the apparent capacitance value calculated for the test material C to that for a very thin layer of good dielectric, C^* . The following equations shall be used to calculate capacitance loading:

The apparent capacitance of reference material (very thin layer of good dielectric) is:

$$C^* = Q_{ref} / V_{ref} \quad (1)$$

Apparent capacitance of test material:

$$C = Q / V \quad (2)$$

Capacitance loading:

$$CL = C / C^*$$

$$CL = (Q / V) / (Q_{ref} / V_{ref}) \quad (3)$$

- where Q_{ref} is the total charge received and V_{ref} the initial surface potential observed on the reference material, Q is the total charge received by the test material, and V is the initial surface potential observed on the test material.

Once a value has been obtained for the apparent capacitance $C^* = Q_{ref} / V_{ref}$ for the reference material in the particular test arrangement this may be used as a reference value in subsequent capacitance loading measurements, so long as all features of the test arrangement remain the same.

F.2 Interpretation of capacitance loading measurements

The values of capacitance loading calculated from each measurement of initial voltage at 100ms

and the associated quantity of charge are plotted against the quantities of charge involved – as illustrated in Figure F1 below. The average slopes of variation for positive and negative polarity are extrapolated to zero charge.

Extrapolation of capacitance loading values to zero charge has been found the best way to match corona charging to tribocharging performance.

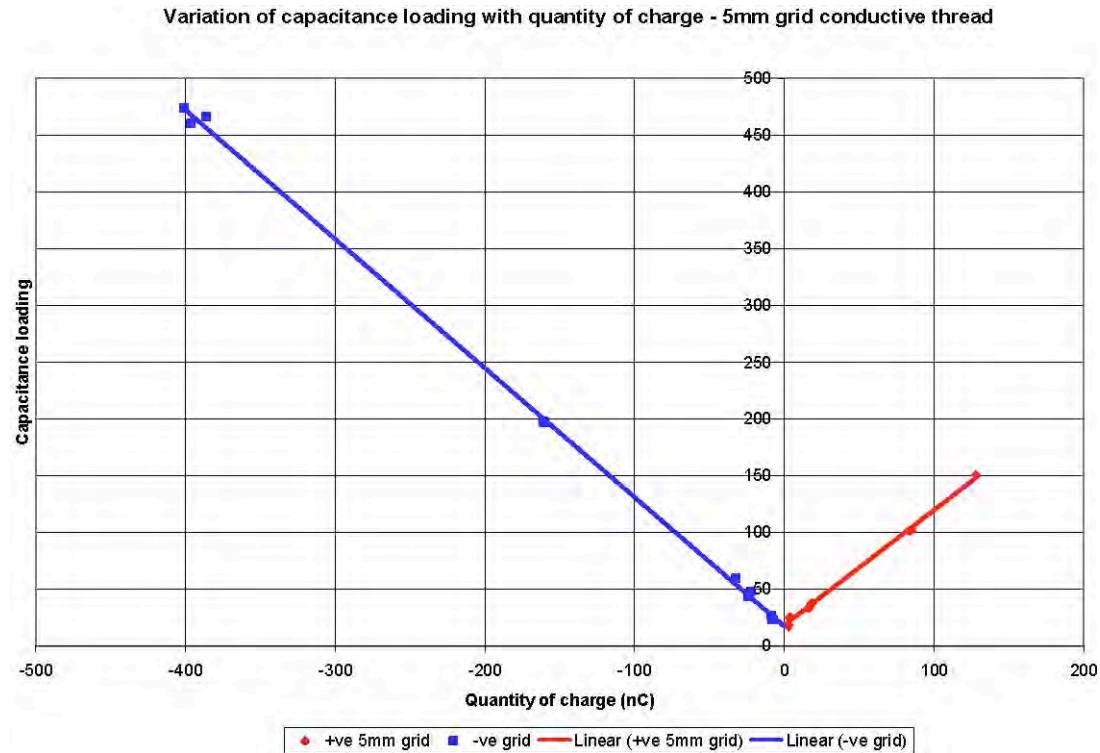

Annex G: (Informative) Bibliography

- [1] R. Gompf "Standard test method for evaluating triboelectric charge generation and decay" *NASA Report MMA-1985-79 Rev 2*, July 1988
- [2] J. N. Chubb "Instrumentation and standards for testing static control materials" *IEEE Trans Ind. Appl.* vol 26 (6) Nov/Dec 1990 p1182.
- [3] J. N. Chubb and P. Malinverni "Experimental comparison of methods of charge decay measurements for a variety of materials" *EOS/ESD Symposium* 1992 p5A.5.1
- [4] J. N. Chubb "Dependence of charge decay characteristics on charging parameters" *'Electrostatics 1995'*, York April 3-5, 1995 Inst Phys Confr Series 143 p103
- [5] J. N. Chubb "Corona charging of practical materials for charge decay measurements" *J. Electrostatics* 37 1996 p53
- [6] J. N. Chubb "The assessment of materials by tribo and corona charging and charge decay measurements" *'Electrostatics 1999'* Univ Cambridge, March 1999 Inst Phys Int Confr
- [7] R. Gompf, P. Holdstock, J. N. Chubb "Electrostatic test methods compared" *EOS/ESD Symposium*, Sept 26-30 1999
- [8] J. N. Chubb "Measurement of tribo and corona charging features of materials for assessment of risks from static electricity" *IEEE Trans Ind. Appl.* 36 (6) Nov/Dec 2000 p1515.
- [9] J. N. Chubb "New approaches for electrostatic testing of materials" *J. Electrostatics* 54 March 2002 p233 (*Proceedings ESA2000 Annual meeting*, Brock University, Niagara Falls, June 18-21, 2000)
- [10] J. N. Chubb, P. Holdstock, M. Dyer "Can cleanroom garments create electrostatic risks?" *'Cleanroom Technology'* 8 (3) March 2002 p38
- [11] J. N. Chubb, P. Holdstock, M. Dyer "Can surface voltages on inhabited garments be predicted" Inst Phys 'Electrostatics 2003' Conference, Heriot-Watt Univ 23-27 March 2003
- [12] J. N. Chubb, P. Holdstock, M. Dyer "Predicting maximum surface voltages on inhabited cleanroom garments in practical use" ESTECH Phoenix 18-21 May 2003
- [13] P. Holdstock, M J D Dyer, J N Chubb "Test procedure for predicting surface voltages on inhabited garments" EOS/ESD Symposium 2003. Las Vegas. 21-25 Sept 2003
- [14] J. N. Chubb "Comments of methods for charge decay measurement" To be published in *J. Electrostatics* 2004
- [15] J. N. Chubb "Experimental comparison of the electrostatic performance of materials with tribocharging and with corona charging" Submitted for publication in *J. Electrostatics* 2004

Annex H: (Normative)

CALIBRATION OF CORONA CHARGE DECAY MEASURING INSTRUMENTATION

H1 Aspects to be calibrated

Calibration of charge decay measurement instrumentation involves two parts:

- 1) calibration of the surface potential sensitivity of the fieldmeter
- 2) calibration of the decay time measurement performance.

H2 Equipment

Calibration of the charge decay measuring instrumentation is made using a plane conducting surface covering the whole test aperture area with a small separation (less than 0,5 mm) below the edge of the test aperture so calibration voltages can be applied. A suitable arrangement is shown below.

H3 Surface potential sensitivity calibration

The surface potential sensitivity calibration is made in terms of a uniform potential on the conducting surface covering the whole test aperture area.

The voltage source shall provide a stable, low ripple voltage of both polarities to at least 1000 V. The voltage measuring system shall cover the measurement of both polarities and be separate from the voltage source so it may be formally calibrated independently. The accuracy of voltage measurement shall be better than 0.2%. The stability of the calibration voltage shall be 0.2%.

H4 Decay time calibration

Calibrated resistors and capacitors are connected in parallel between earth and the conducting calibration plate over the test aperture. The resistors and capacitors shall be of good quality, with linear characteristics with voltage and be capable of withstanding voltages up to 3 kV.

Decay time values in seconds are derived from the product of the values of the resistors (ohms) and capacitance (farads). Decay time values shall be provided for each decade of time over the main operating range of the instrument. To cover the range of interest of materials used for static control the decay time values provided should cover the range 0.1 s to 100 s.

Formal calibration of the resistors and capacitors shall be made in the equipment as used for calibration of the charge decay instrumentation.

H5 Calibration procedure

The charge decay measuring instrument is mounted on the calibration equipment, switched on and allowed to stabilise. Connect the calibration plate to earth and measure the initial 'zero' surface potential reading by the fieldmeter. Apply calibrated voltages to the plate to give readings at well spaced voltage levels from 50 V to 1000 V. Repeat measurements for the other voltage polarity.

Connect a combination set of resistance and capacitance values from earth to the calibration plate. Operate the charge decay measuring instrument to apply sufficient charge to the calibration plate to achieve an initial peak surface potential suitable for decay time measurement. Initial surface potentials in the range 100 V to 1000 V are convenient. Measure the time from the initial peak surface potential to $1/e$ of this using the normal instrument charge decay time measurement facilities. If both electronic and software decay time measurement facilities are available then both shall be used together.

At least 3 decay time measurements shall be made for each charge polarity for each decay time value setting. From each set of 6 readings the average decay time value and the standard deviation shall be calculated.

H6 Calibration Certificate information

The calibration certificate shall include to following information:

- a) name of organisation issuing the certificate
- b) Certificate number
- c) Customer name
- d) Instrument type number
- e) Instrument serial number
- f) Date of calibration
- g) Name and signature of authorised signatory
- h) Method of calibration used
- i) Assessment of overall accuracy
- j) Reference information on date and source of calibration of measuring instruments used and accuracy of their calibration
- k) Table of results as:

- list of applied voltages, positive and negative

- readings obtained: table of decay times with standard deviations and values from combinations of calibrated resistors and capacitors

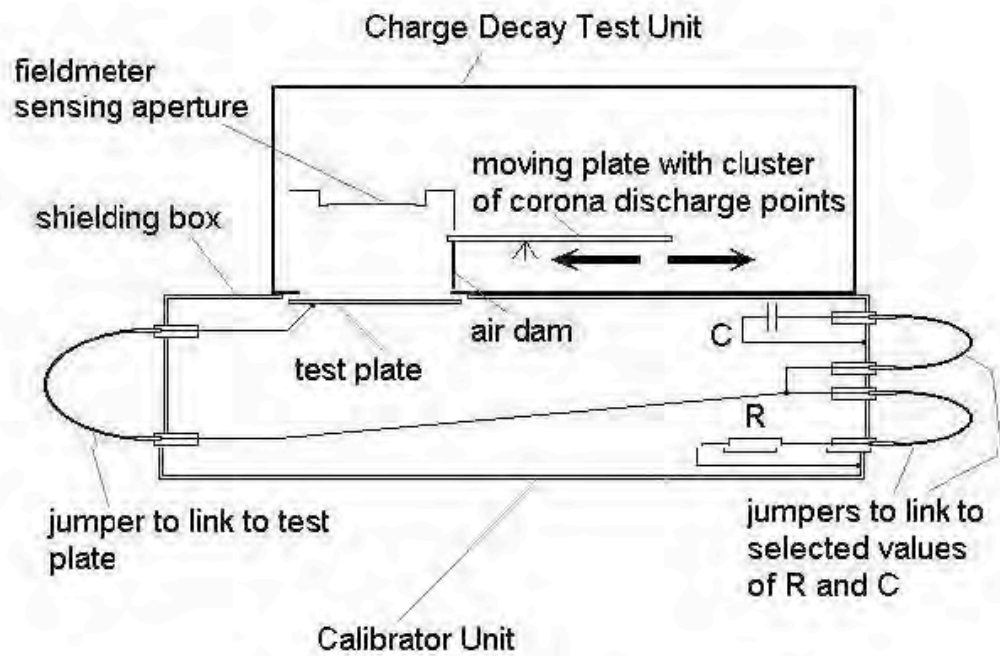

Annex J: (Normative) CALIBRATION OF CORONA CHARGE TRANSFER MEASURING INSTRUMENTATION

J.1 Aspects to be calibrated

Calibration of instrumentation for measurement of the corona charge received by samples involves two parts:

- 1) calibration of the charge sensitivity of the ‘induction’ and ‘conduction’ charge measurement circuits
- 2) calibration of the interpretation of induction charge observations.

J.2 Induction and Conduction charge measurement sensitivity

A defined quantity of charge is provided by charging a calibrated capacitor to a defined voltage. Charge calibration involves discharging this capacitor directly to the electrodes involved in ‘conduction’ and in ‘induction’ charge measurement. If the charge measurement circuits are ‘virtual earth input’ circuits then all the charge on the capacitor is transferred to the charge measurement circuit, and the signal output can be compared to the known quantity of charge input.

J.3 Relative sensitivity of ‘induction’ charge measurement

The relative sensitivity of ‘induction’ charge observations is the charge signal measured compared to the quantity of charge placed on the sample surface at the position of charge deposition. This is best determined by making charge decay studies with the charge decay test unit mounted on the charge measuring sample support using a thin test sample that is a fairly homogeneous dielectric and has a charge decay time of several seconds. Charge measurement signals will initially be solely a ‘induction’ charge signal. This will progressively move to become just a ‘conduction’ charge signal. Since the total charge is constant the relative sensitivity factor is the factor by which the decaying ‘induction’ signal needs to be multiplied so that when this is added to the increasing ‘conduction’ signal the sum, that is the total charge value, is stable over the time of observation.

The precise sensitivity of ‘induction’ charge measurements is assessed using a thin sample of a simple dissipative material (for example paper, cellophane or cling film), with a decay time of a few seconds. The variations of conduction Q_c and induction Q_I signals are numerically recorded over the initial period of charge decay, for example to the $1/e$ time. Spreadsheet modelling may then be used to find the numerical factor, f_I , by which instantaneous ‘induction’ signals need to be multiplied so that when added to corresponding instantaneous ‘conduction’ signals a total signal Q_{tot} is achieved that does not vary over the observation time.

$$Q_{tot} = Q_c + f_I * Q_I \quad (1)$$

The process is illustrated in Figure J2.

Once a value has been obtained for the factor f_1 , this may be used as a reference value in subsequent charge measurements, so long as all features of the test arrangement remain the same.

J4 Calibration Certificate information

The calibration certificate shall include the following information:

- a) name of organisation issuing the certificate
- b) Certificate number
- c) Customer name
- d) Instrument type number
- e) Instrument serial number
- f) Date of calibration
- g) Name and signature of authorised signatory
- h) Method of calibration used
- i) Assessment of overall accuracy

- j) Reference information on date and source of calibration of measuring instruments used and accuracy of their calibration
- k) Table of results as a list of applied quantities of charge with associated readings for positive and negative polarities for both the induction and the conduction electrodes

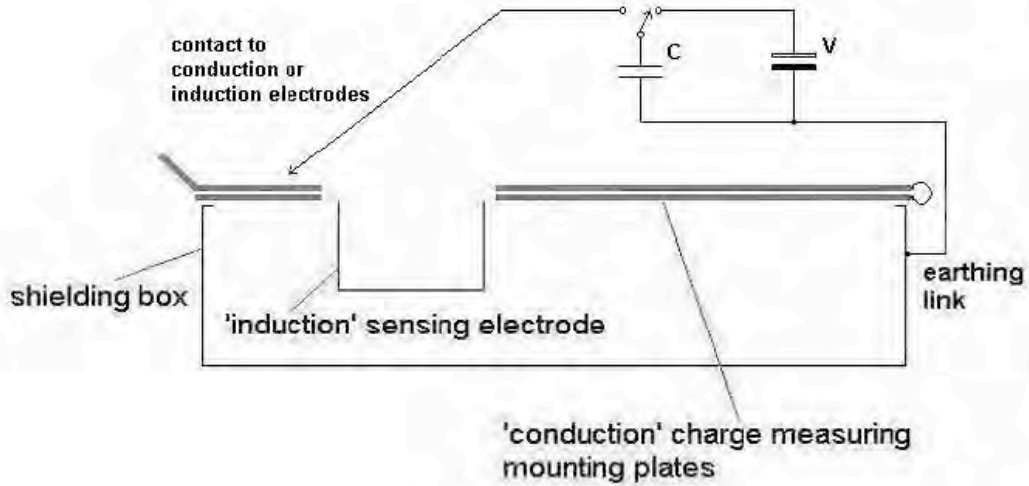

Figure J1 – Arrangement for calibration of charge sensitivity

Factor to match 'induction' charge measurement = 2.0

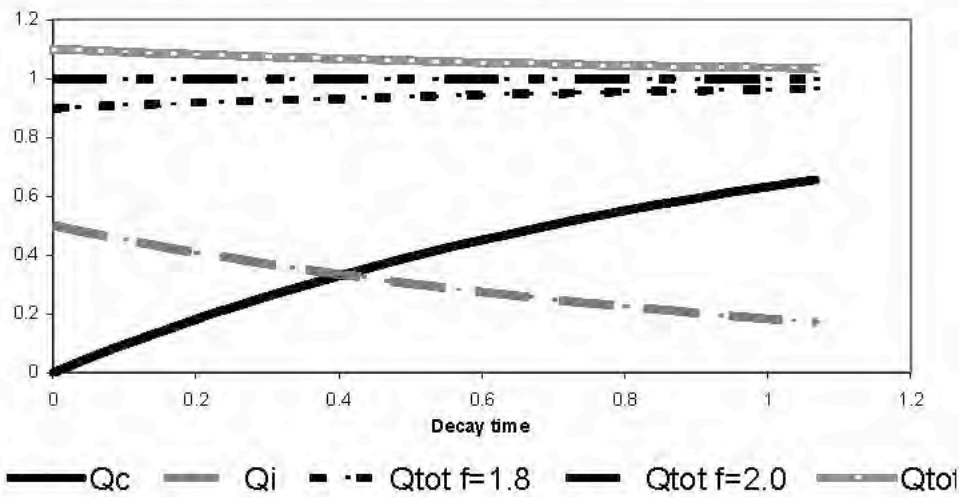

Figure J2: Adjustment of factor for matching induction to conduction measurements